

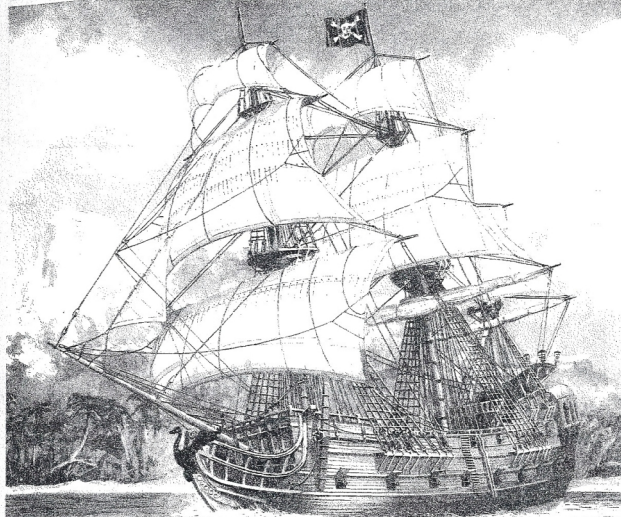

№9031

MADE IN RUSSIA



# PIRATE SHIP «BLACK SWAN»

SCALE 1:72

**ATTENTION - Useful advice!**

Study the instructions carefully prior to assembly. Remove parts from frame with a sharp knife or a pair of scissors and trim away excess plastic. Do not pull off parts. Assemble the parts in numerical sequence. Use plastic cement ONLY and use cement sparingly to avoid damaging the model. Paint small parts before detaching them from frame. Remove paint where parts are to be cemented.

**ACHTUNG - Ein nützlicher Rat!**

Vor der Montage die Zeichnung aufmerksam studieren. Die einzelnen Montageteile mit einem Messer oder einer Schere vom Spritzling sorgfältig entfernen. Eventuelle Grate werden mit einer Klinge oder feinem Schmirgelpapier beseitigt. Keinesfalls die Montageteile mit den Händen entfernen. Bei der Montage der Tafelnummerierung folgen. Die Nummer der schon montierten Teile auf dem Spritzling ankreuzen. Bitte nur Plastikklebstoff verwenden.

**ATTENZIONE - Consigli utili!**

Prima di iniziare il montaggio, studiare attentamente il disegno. Staccare con molta cura i pezzi dalle stampate, usando un taglia-balsa oppure un paio di forbici e togliere con una piccola lima o con carta vetro fine eventuali sbavature. Mai staccare i pezzi con le mani. Montarli seguendo l'ordine della numerazione delle tavole. Eliminare dalla stampata il numero del pezzo appena montato, facendogli sopra una croce.

**ATENCION - Consejos útiles!**

Estudiar las instrucciones cuidadosamente antes de comenzar el montaje. Separar las piezas de las bandejas con un cuchillo afilado o un par de tijeras, y retirar el exceso de plástico o rebaba. No arrancar las piezas. Montar las piezas en orden numérico. Utilizar SOLAMENTE pegamento para plástico y en poca cantidad para evitar que se dane el modelo. Pinar las piezas pequeñas antes de separarlas de la bandeja. Retirar la pintura de los lugares por donde se deban pegar las piezas.

**ATTENTION - Conseils utiles!**

Avant de commencer le montage, étudier attentivement le dessin. Détacher avec beaucoup de soin les morceaux des moules en usant un massicot ou bien un pair de ciseaux et couper avec une petite lame ou avec de papier de verre fin ébarbages éventuels. Jamais détacher les morceaux avec les mains. Monter les en suivant l'ordre de la numération des tables. Éliminer de la moule le numéro de la pièce qui vient d'être montée, en le blifant avec une croix. Employer seulement de la colle pour polystyrol.

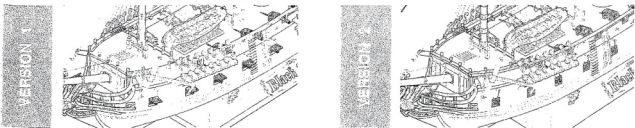
**THE MODEL ASSEMBLING VERSIONS**

YOU WILL NEED THESE TOOLS TO ASSEMBLY A MODEL

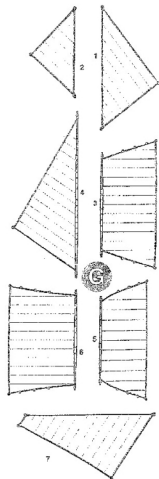
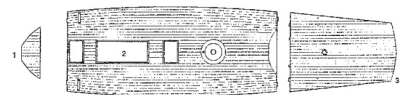
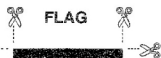
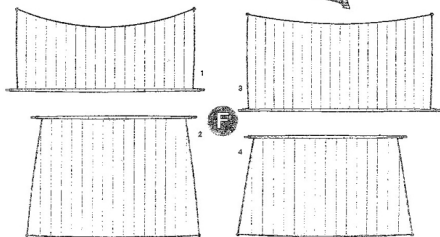
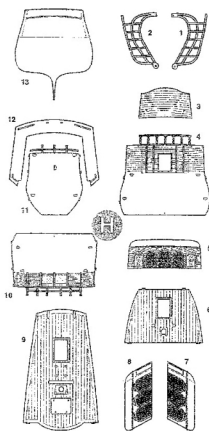
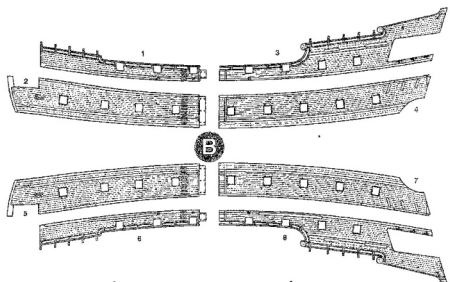
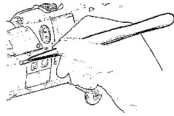
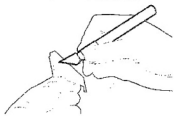
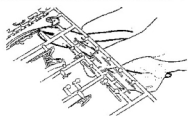

← To glue a detail on the specified place

← To establish a detail on the specified place without glue



Repeat assembling at the other side

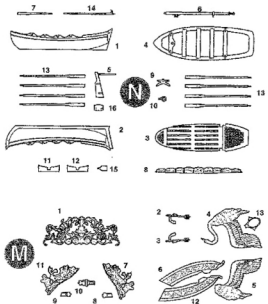
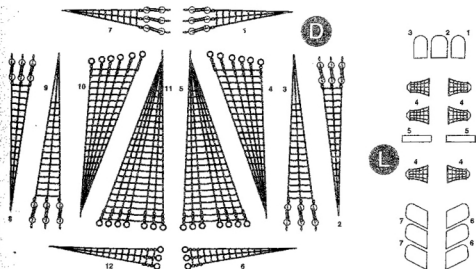
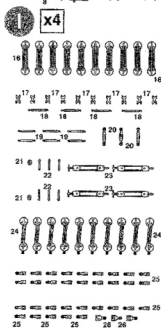
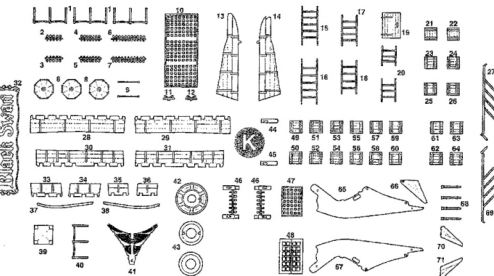
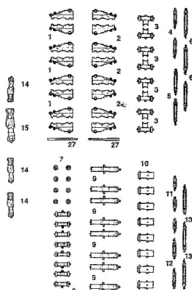
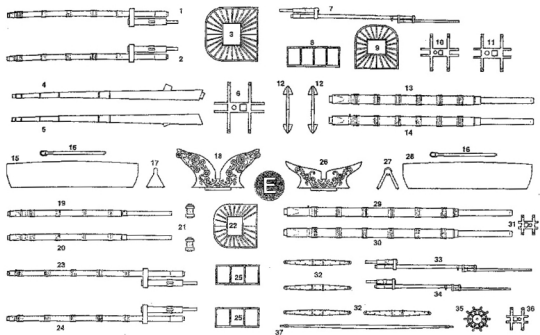

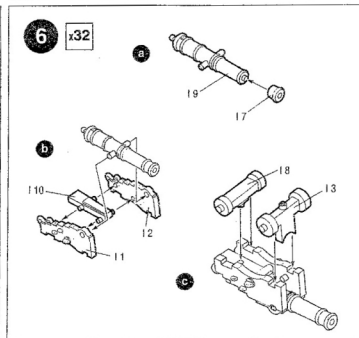
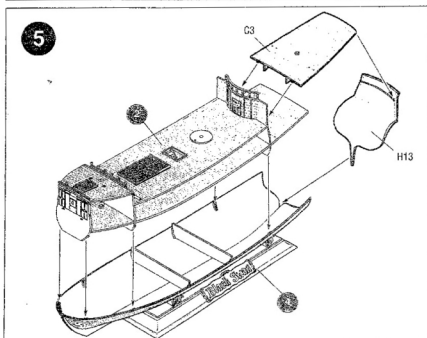
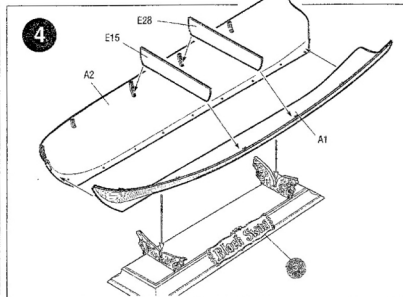
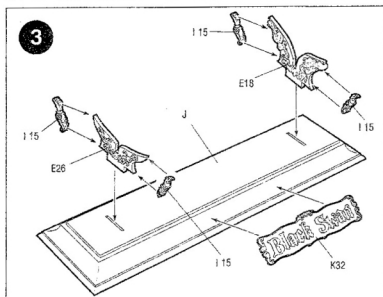
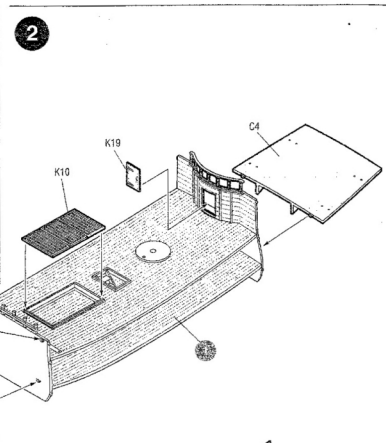
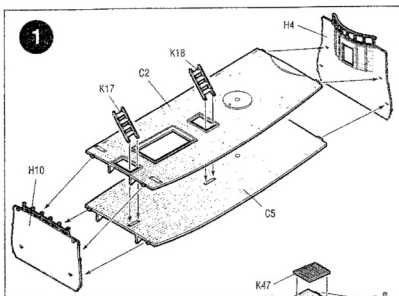



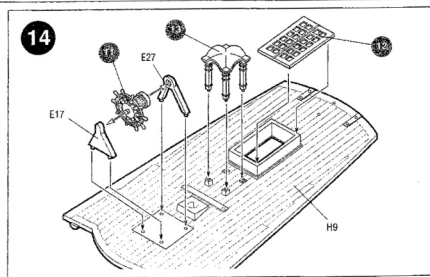
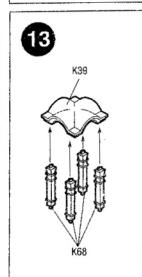
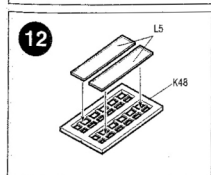
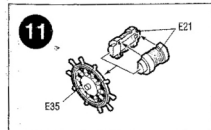
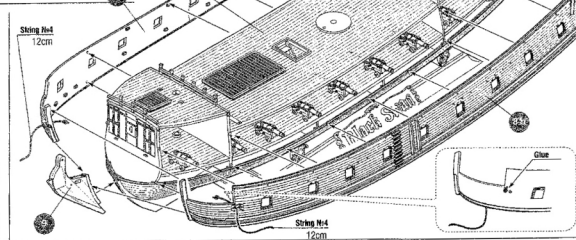
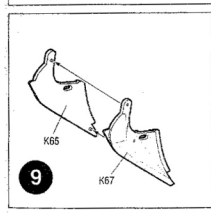
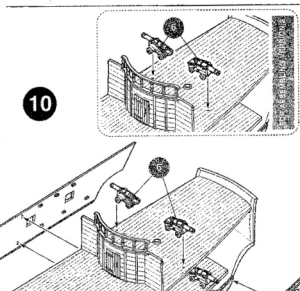
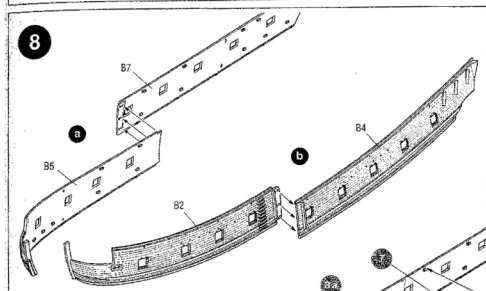
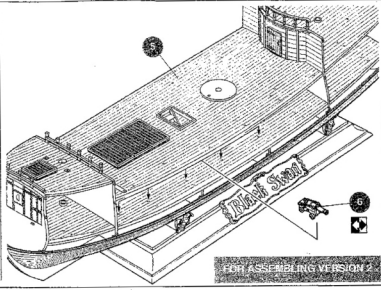
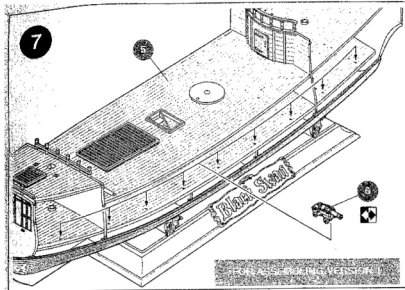

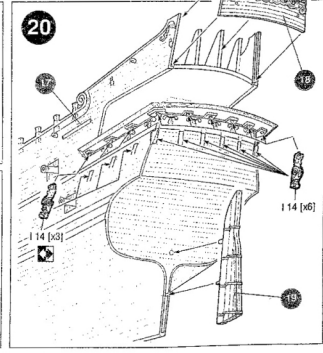
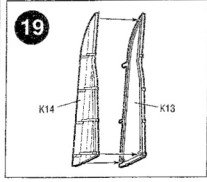
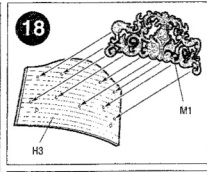
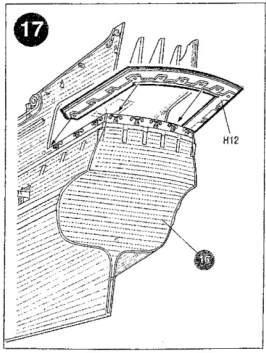
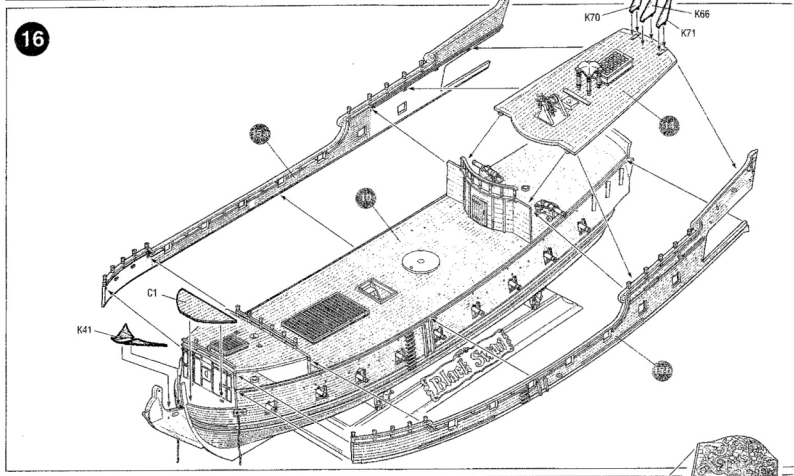
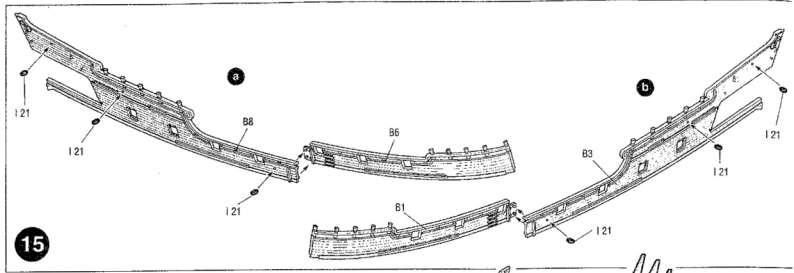

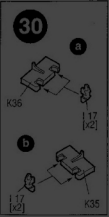
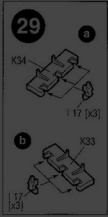
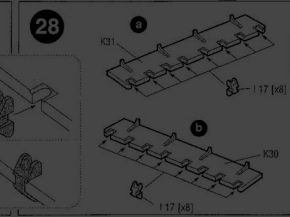
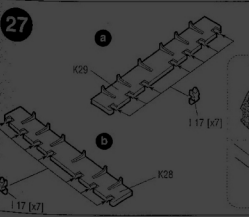
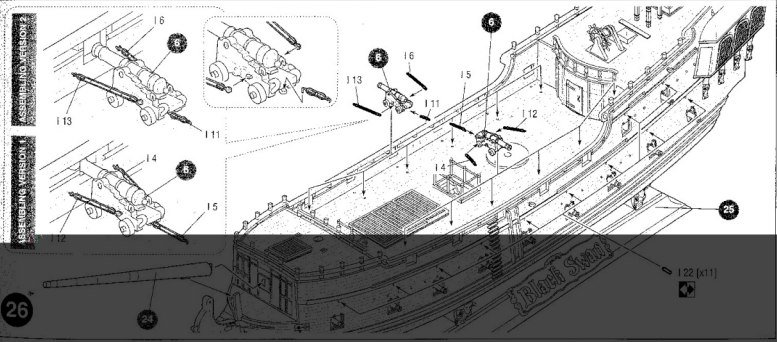
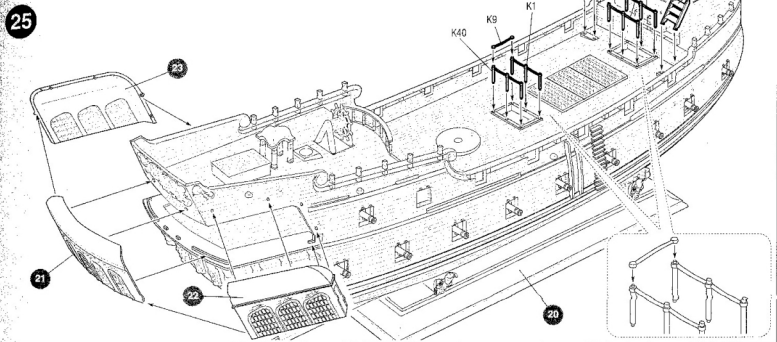
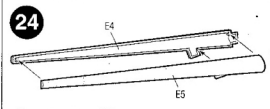
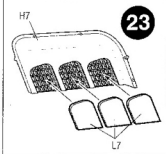
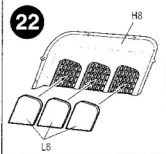
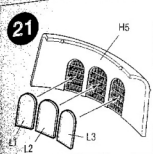

31

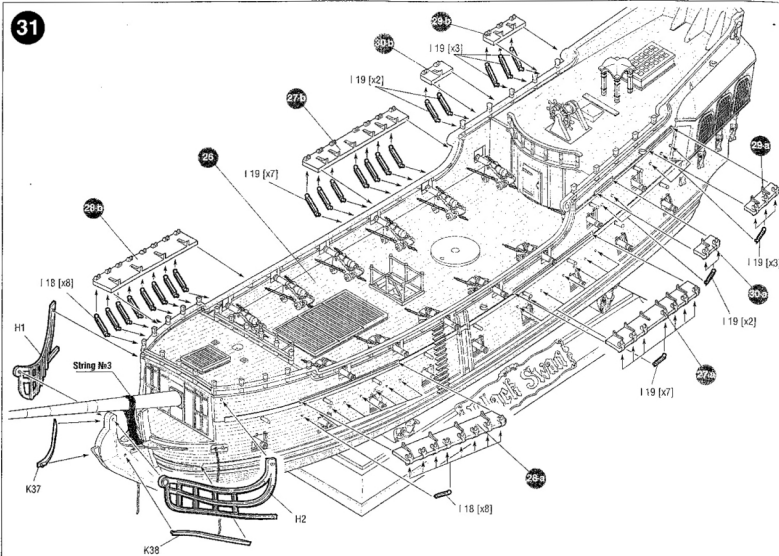

32

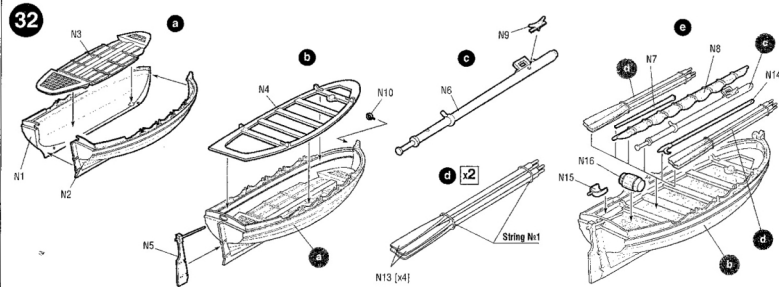

33

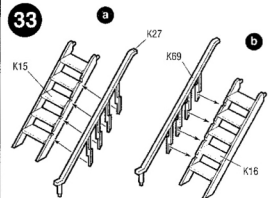

34

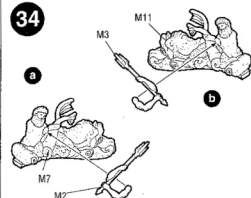

35

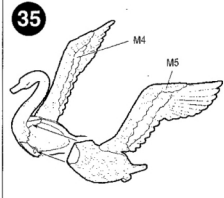

36

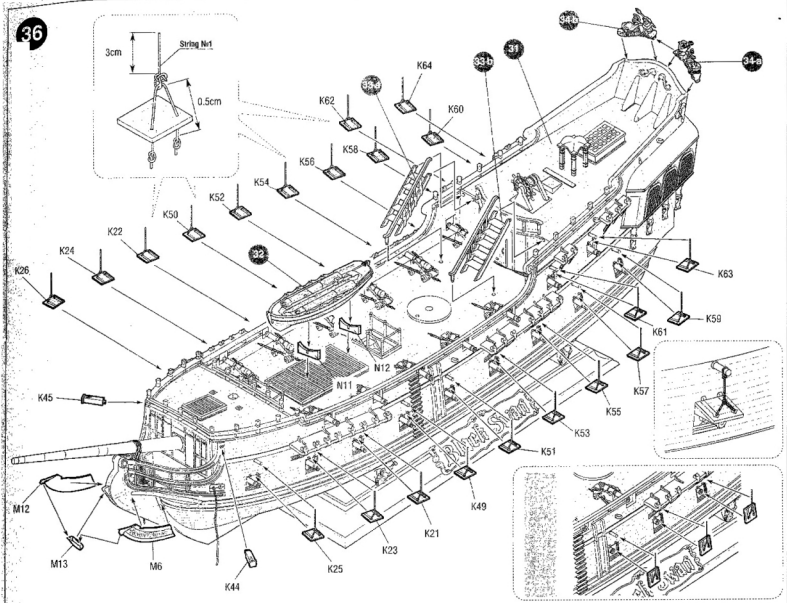

37

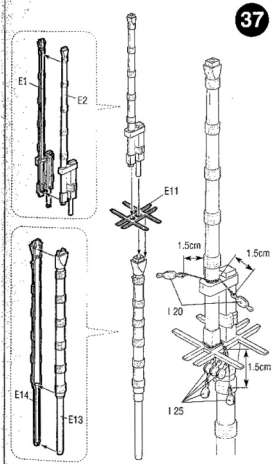

38

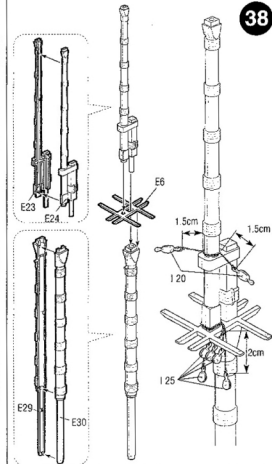

39

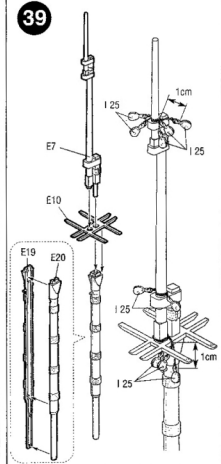

40

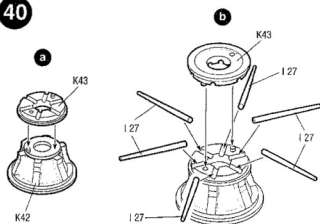

41

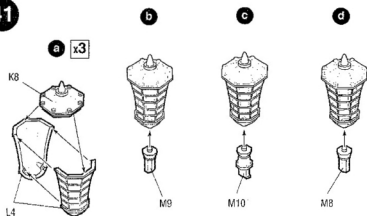

42

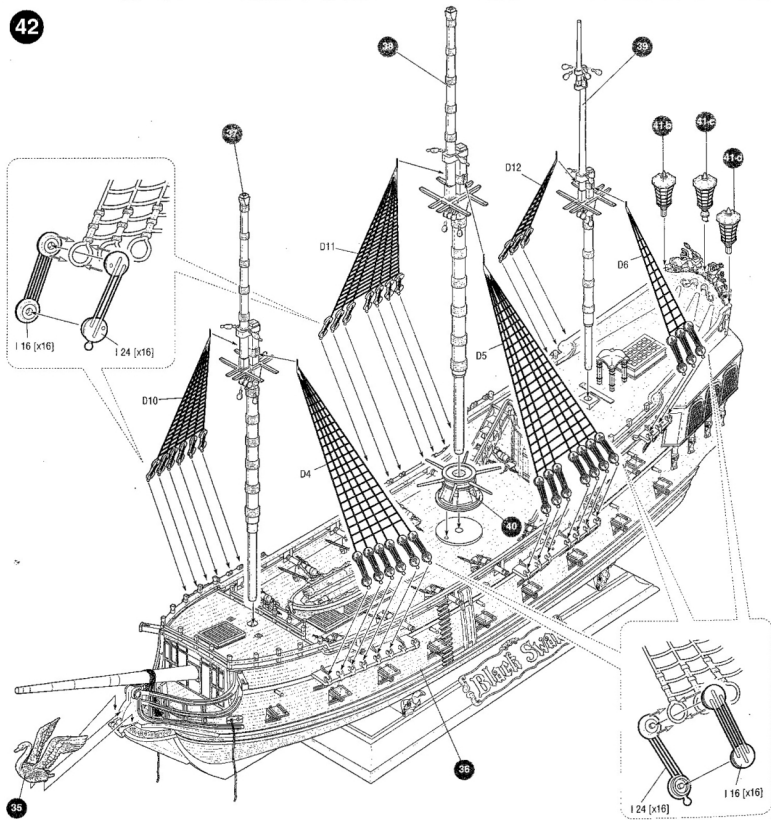

43

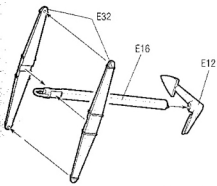

44

x8

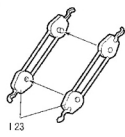

45

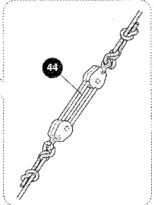
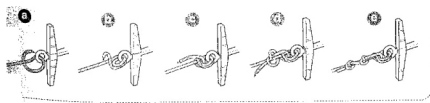
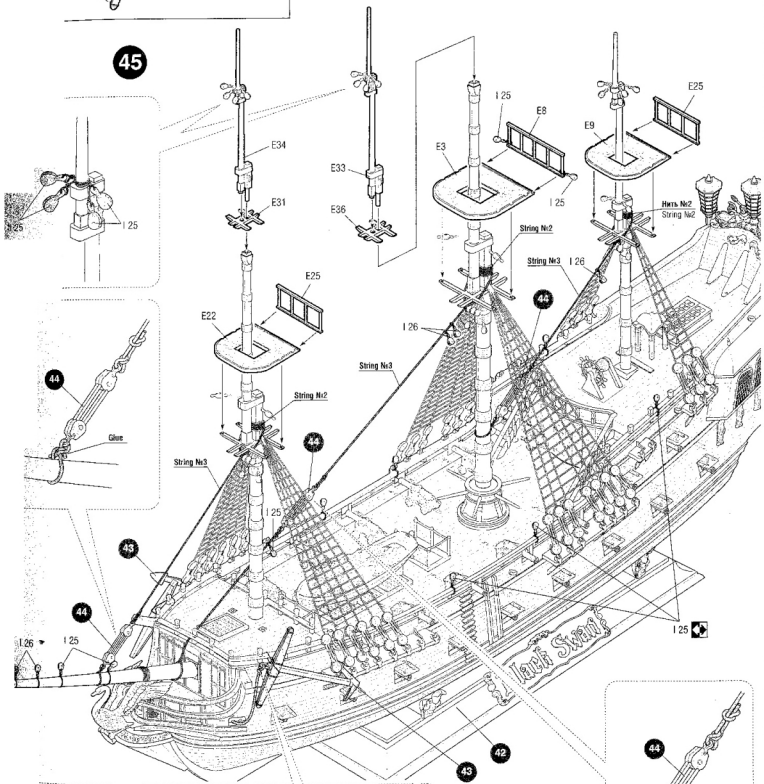

46 x8

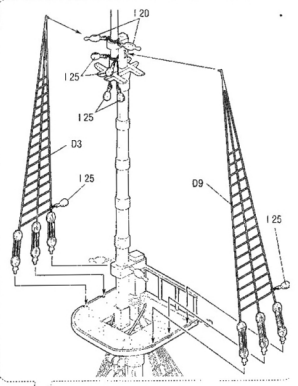
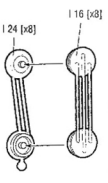
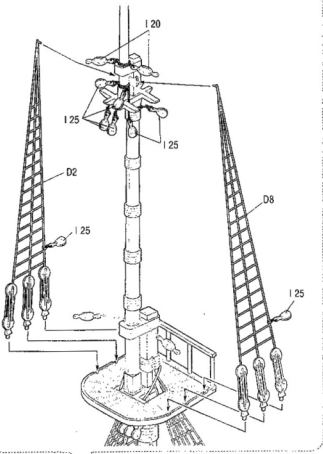

47

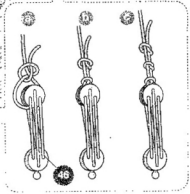
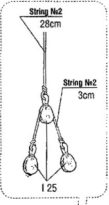
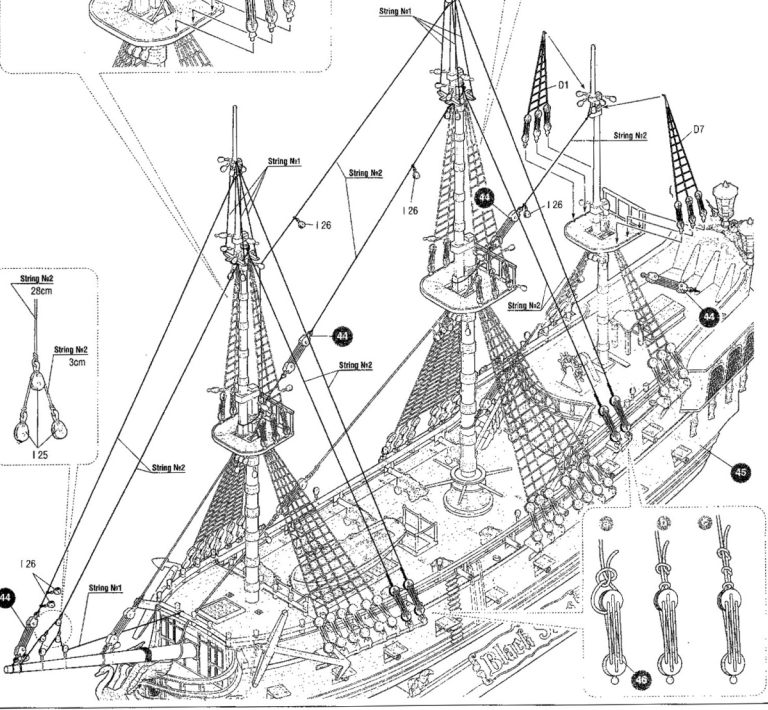



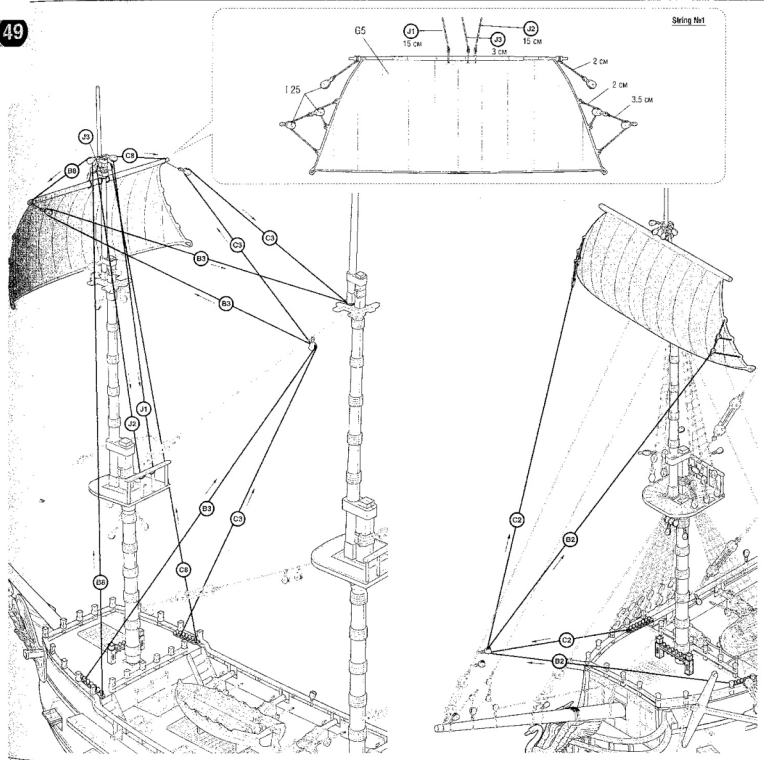
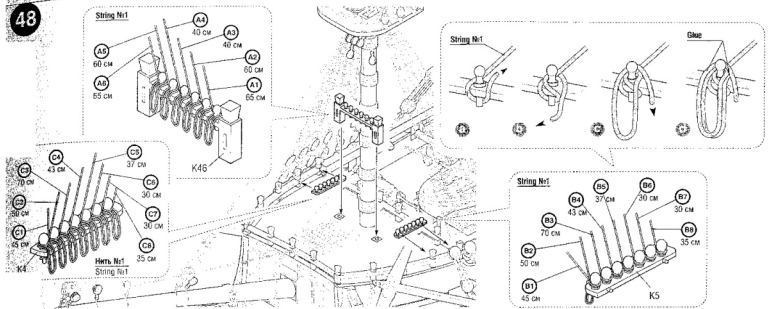

String Nr1

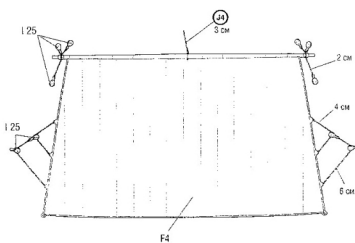

50

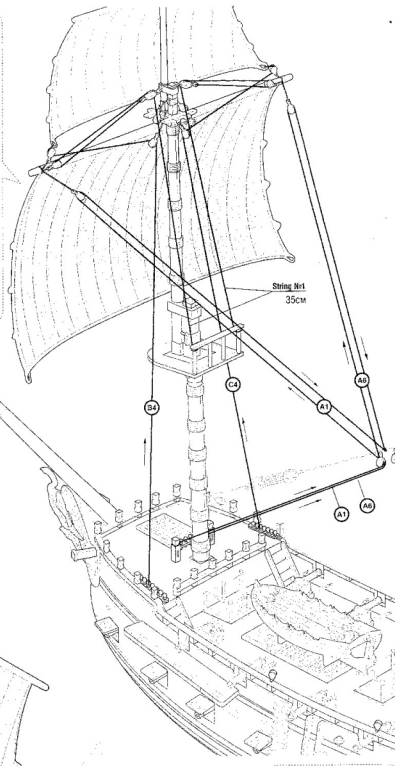

String Nr1  
35cm

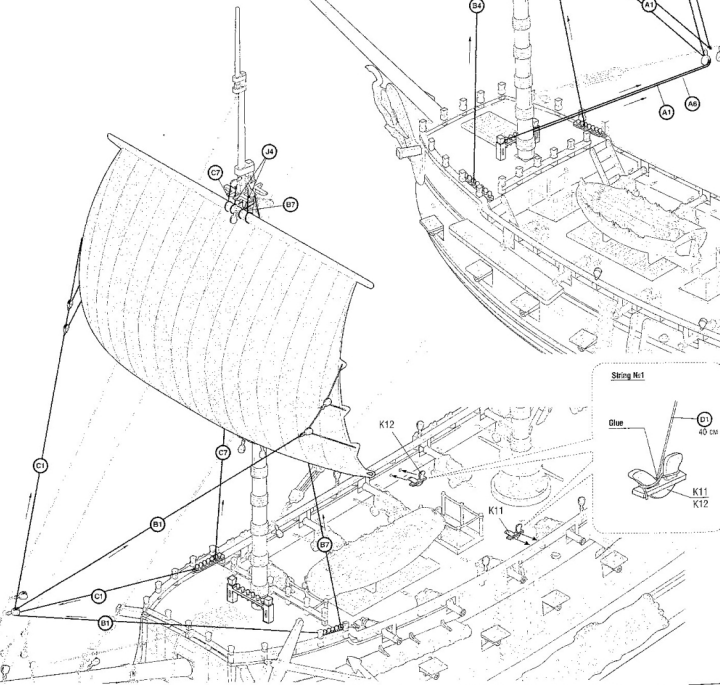

String Nr1

Glue

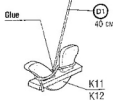

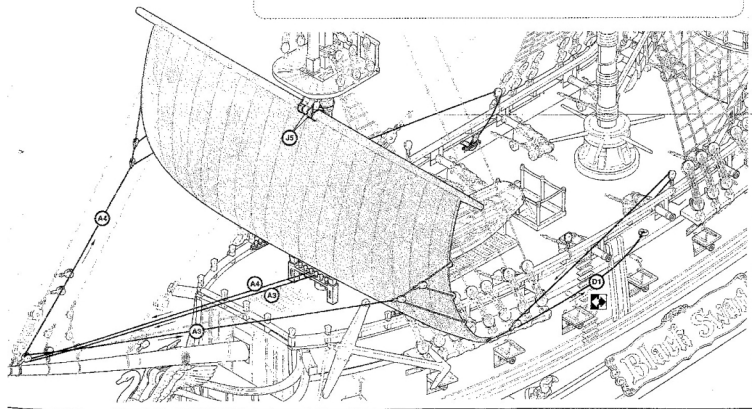
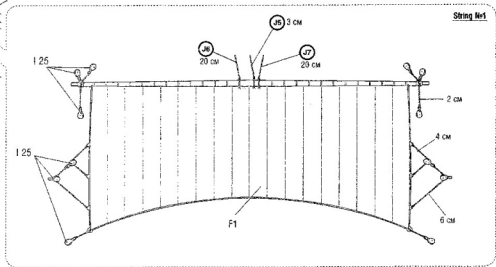
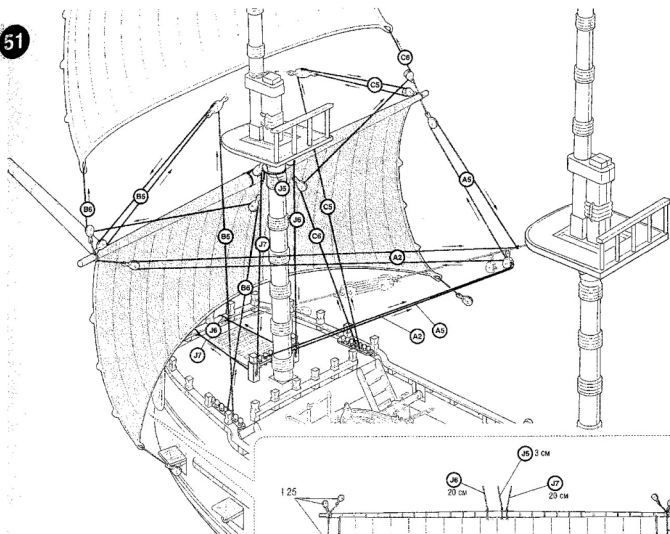

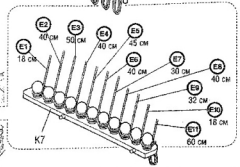
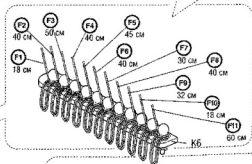
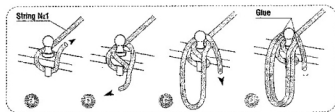
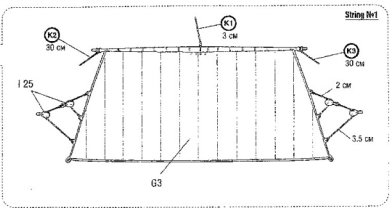
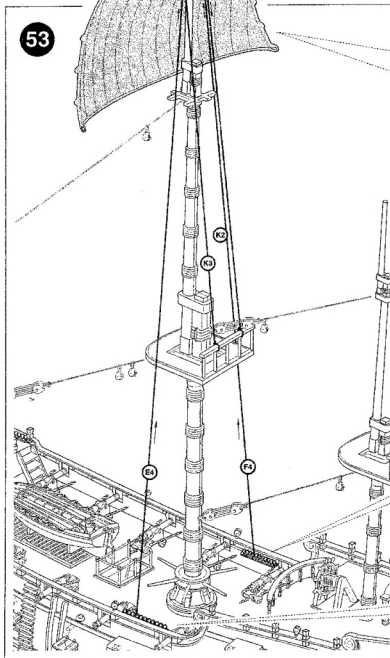
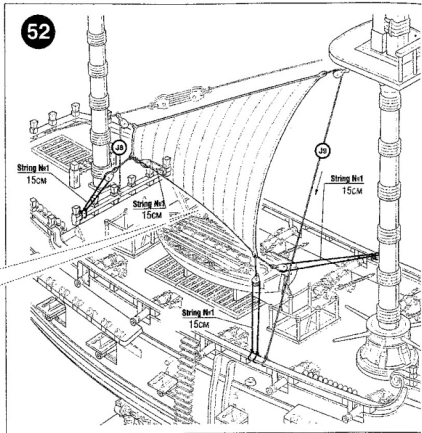
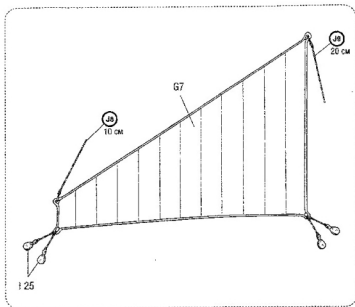

String Nr1

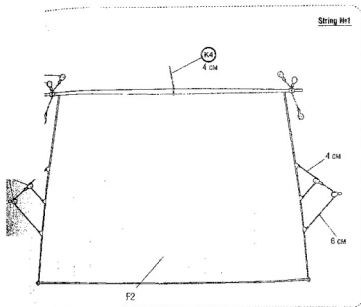

String Nr1

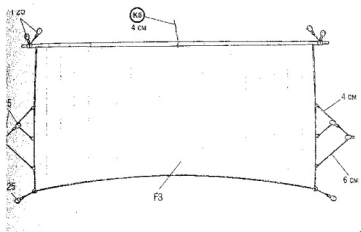

54

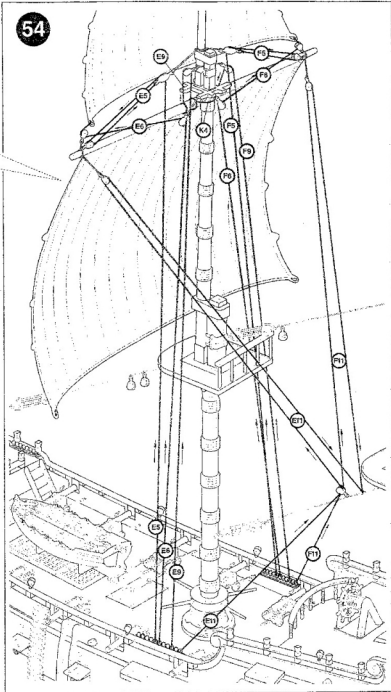

55

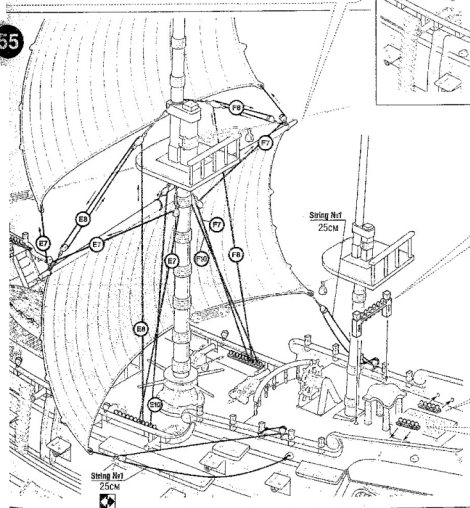

String Nr1  
25CM

String Nr1  
25CM

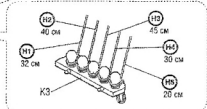
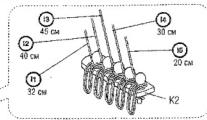
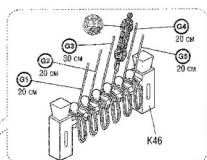

56

FLAG

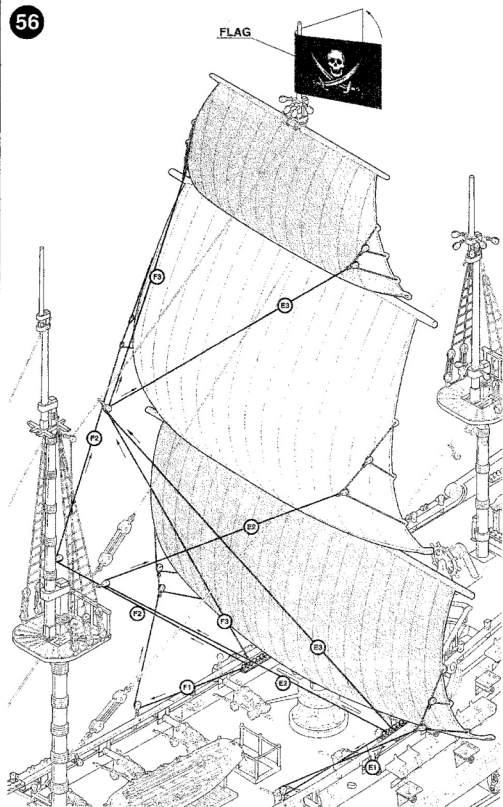

String M1

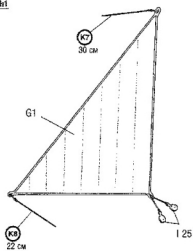

58

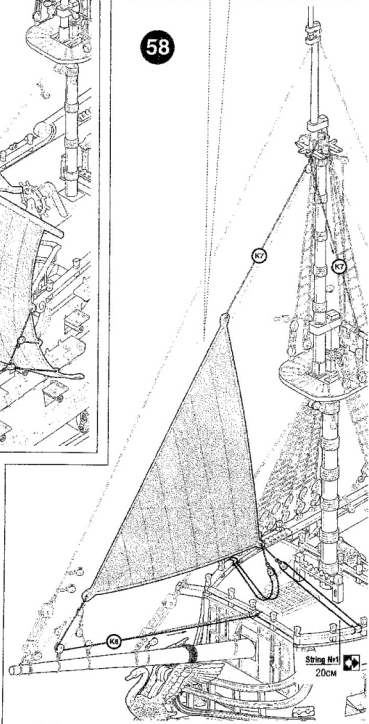
String M1  
20cm

57

String M1

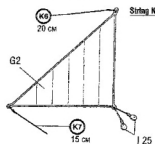
String M1  
15cm

String Net

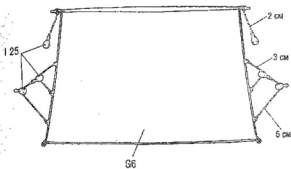

String Net



String Net

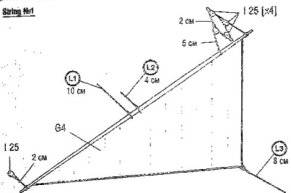

59

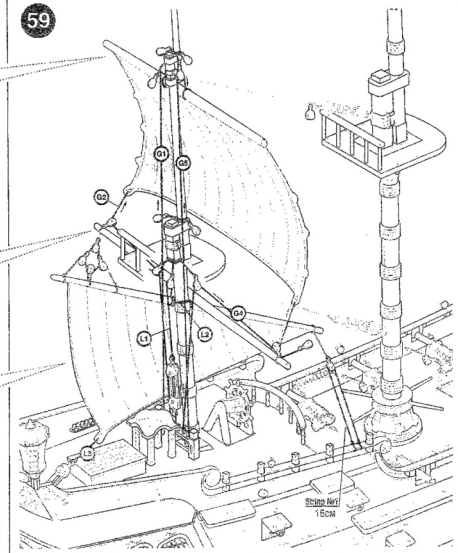

60

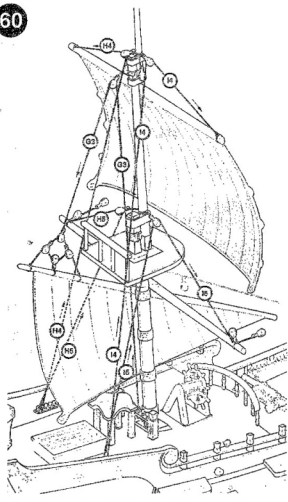

61

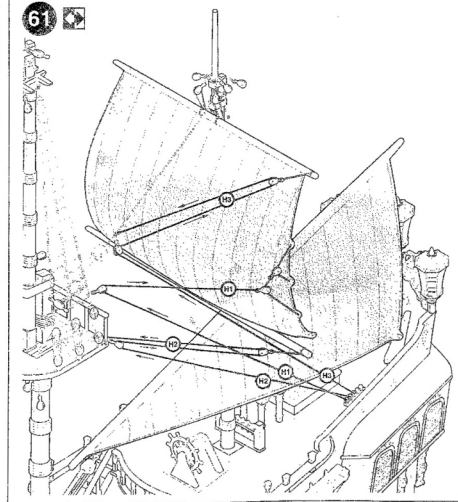

# THE MODEL PAINTING

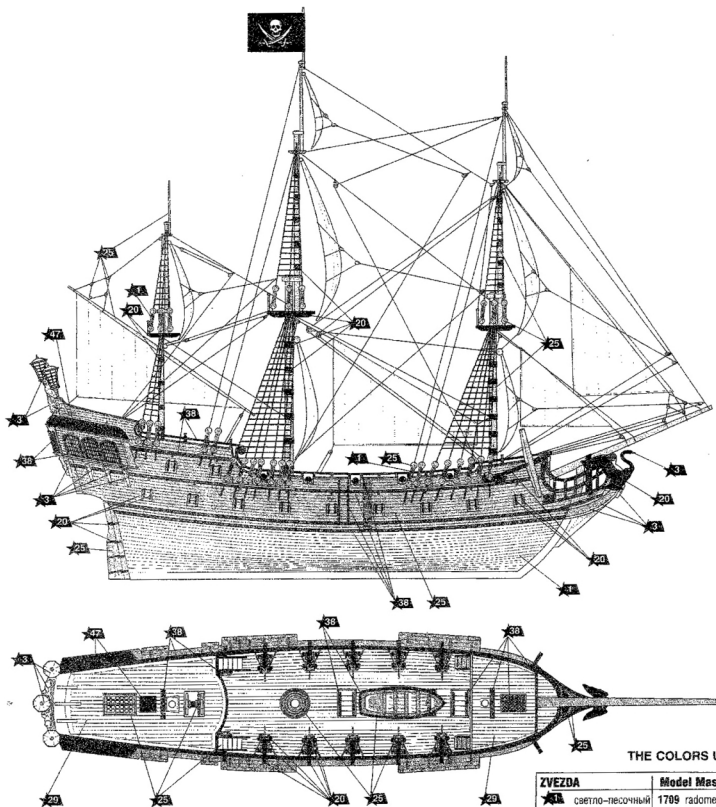

## THE COLORS USED

ZVEZDA	Model Master
★17	1709 radome tan
★33	1744 gold
★20	1749 black
★25	1735 wood
★29	1706 sand
★30	1583 rubber
★17	2030 true blue